

19015-CT-12V100Ah100A Battery Pack Spec

Model : 19015-CT-12V100Ah100A

Customer P/N: _____

Nominal Voltage: 12.8V

Capacity: 100Ah

1. Application	4
2. Basic Information	4
3. Electrical Characters	4
4. Certification	5
5. Mechanical Information	5
5.1. Sample Picture	5
5.2. Drawing of Label	5
5.3. Drawing Packing	6
6. Caution and prohibition	6
7. Warranty	6
8. Handling Instruction Guide for LiFePO4 Battery Pack	6
8.1. General	6
8.2. Storage of pack	6
8.3. Charging pack	7
8.4. Protection from unexpected damaged to pack	7
8.5. For Safety	7

1. Application

12V

For replacement the 12V lead-acid battery in power backup system.

Remark: This spec is for the Independent Products from CTECHi Group. Any upgrade without notification. Please contact with our sales to get the updated spec.

2. Basic Information

Description: Rechargeable LiFePO4 battery pack
 Cell Type: AC EA01 50Ah
 Chemistry: LiFePO4
 PCM: Yes
 Cell configuration: 2P4S
 Voltage Nominal: 12.8V
 Capacity Nominal: 100Ah
 Energy: 1280Wh

Protection:

- A. Over Charge Protection
- B. Over Discharge Protection
- C. Over Current Protection
- D. Short Protection

3. Electrical Characters

Items	Parameter
Charging Method	CC-CV
Charging Voltage	14.4±0.2V
Over Charging Protect	3.9±0.025V
Standard Charging Current	20A (0.2C)
Max. Charging Current	100A
Cut-off Charging Current	2A (0.02C)
Standard Discharging Current	20A (0.2C)
Max. Discharging Current	100A
Discharging cut-off Voltage	8V
Over Charge Current	250±30A
Over Discharge Current	250±30A
Over Discharging Protect	2.0±0.08V
Internal Resistance	<180mOhm
balancing voltage	3.60±0.05V
balancing current	70±5mA

Standard Charge Temperature	0~45℃
Standard Discharge Temperature	-20~60℃
Storage Humidity	65%RH not condensed
Storage Temperature	-20~60℃
Weight	About – 11kg

4. Certification

T.B.D.

5. Mechanical Information

5.1. Sample Picture

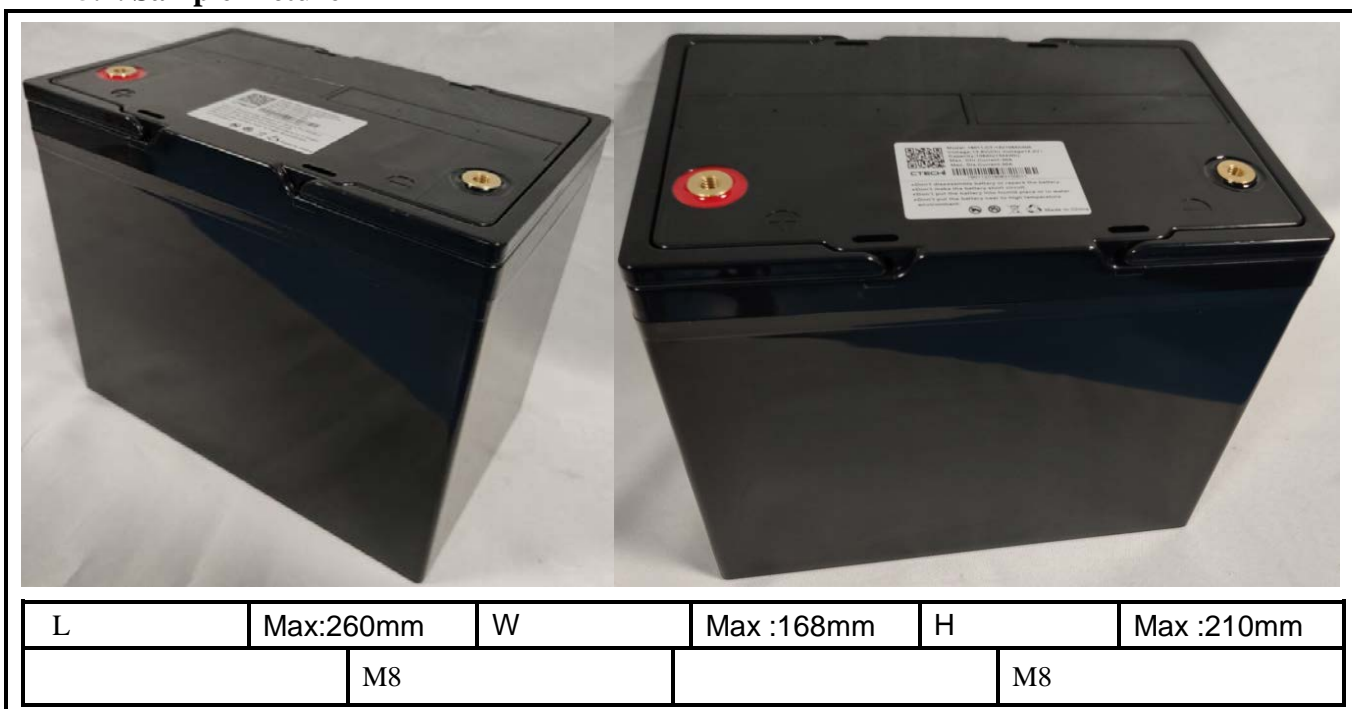

5.2. Drawing of Label

PET 70mm, 50mm :



5.3. Drawing Packing

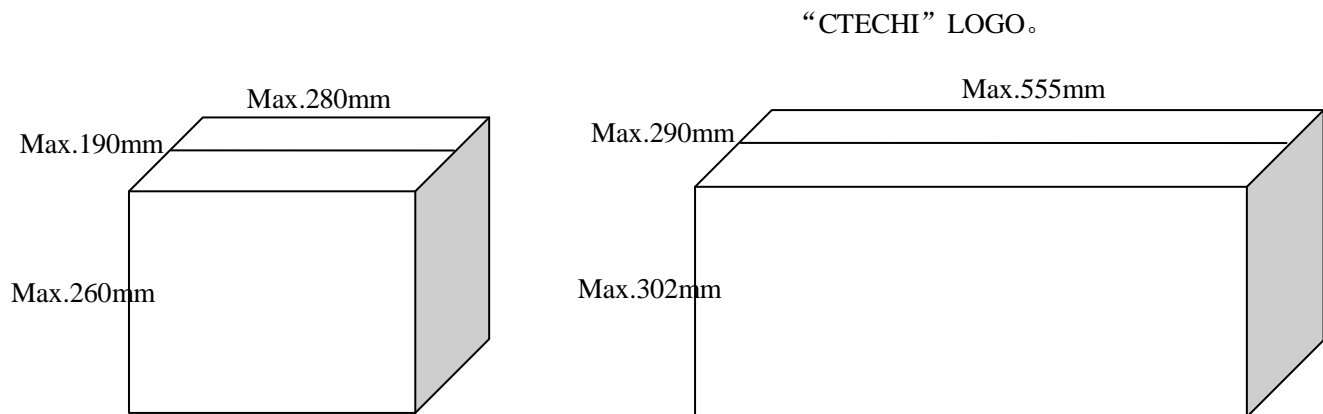

6. Caution and prohibition

Before using and handling the pack, see carefully attached “Handling Instruction for Rechargeable Lithium ion battery Pack”.

For safety reasons rechargeable batteries are not shipped in a low remaining capacity state. Charge before using.

Do not connect multiple battery packs as parallel or serials for using. This might damage the battery pack, even your equipment's.

7. Warranty

Manufacturer will be responsible for replacing the battery pack against defects or poor workmanship for 12 months from the date of shipping. Any other problem caused by malfunction of the equipment or misuse of the battery is battery is not covered under this warranty.

8. Handling Instruction Guide for LiFePO4 Battery Pack

8.1. General

Battery packs supplied by CTECHI or CPKD have to be handle carefully according to the specification. Here are some more to be followed.

8.2. Storage of pack

The packs are requested to be stored under the following conditions:

- a. Indoor storage in a cool circumstances without direct sun light on the packs or cartons.
- b. Store batteries in a dry location with low humidity, and a temperature range of - 20°C to +30°C. In case of the long term storage.

- c. As long-term storage can accelerate battery self-discharge and lead to the deactivation of the batteries. To minimize the deactivation effect, store battery packs in a temperature range of +10°C to +30°C.
- d. When charging for the first time after long-term storage, deactivation of the packs may have led to decreased capacity. Recover such packs to original performance through repeating several cycles of full charging and discharging.
- e. When store packs for more than 6 month, charge at least once charring require per 6 months to prevent leakage and deterioration in performance due to self-discharging.

8.3. Charging pack

- a. Use suitable charger with the specified voltage and current. We strongly recommend CTECH and CPKD smart battery charger. We can recommend the usage or specification of the charger manufacturing. If you want to get the information about it, please contact us.
- b. Never attempt reverse charging. Charring with polarity reversed can cause a reversal in battery polarity, causing gas pressure inside of the battery to rise, which can be lead to leakage of the batteries in the pack.
- c. Avoid overcharging. Repeated overcharging can be lead to deterioration in pack performance. And Over-heat occurred.
- d. Charging efficiency drops at temperatures above 40°C.

8.4. Protection from unexpected damaged to pack

- a. (+) and/or (-) terminals must not be connected in metal wire, necklace, chains.
- b. Do not drop packs from height in order to prevent them from possible malfunction or damage.
- c. Do not twist or bend packs in order to prevent possible damage.

8.5. For Safety

- a. Do not disassemble packs.
- b. Do not use pack when something abnormal found such as smells, deformation, discoloration, and so on.
- d. Do not re-use LiFePO₄ cells or other parts after removing from the packs.
- e. When the electrolyte leakage occurs, do not touch the liquid.

- f. Once watered, packs may have potential malfunctions. Do not use those packs.
- g. Do not have packs in the hot-temperature (60°C or more).
- h. Do not put packs into fire.
- i. Do not crush/nail pack.
- i. Do not apply solder directly to packs.