

20330-CT-51.2V12Ah Battery Pack Spec

电池包规格书

Model :
型号: 20330-CT-51.2V12Ah

Customer NO:
客户代码: C10235

Customer P/N:
客户型号: _____

Nominal Voltage:
标称电压: 51.2V

Capacity:
容量: 12Ah

Draft 起草	Checking 审核	Approved 批准	Customer Confirmation 客户确认
Kenny			

目录

1. Application 应用	4
2. Basic Information 基本信息	4
3. Electrical Characters 电气特性.....	4
4. Certification 认证	5
5. System Block Diagram 系统框图.....	5
6. Mechanical Information 结构信息	5
6.1. Sample Picture 样品照.....	5
6.2. Outline 外框信息	5
6.3. Pack Assemble 电池包组装要求.....	5
6.4. Drawing of Label 标签图.....	6
6.5. Packing 包装信息	6
7. Caution and prohibition 注意事项.....	6
8. Warranty 保修.....	6
9. Handling Instruction Guide for LiFePO4 Battery Pack 磷酸铁锂电池包使用说明书	6
9.1. General 总括.....	6
9.2. Storage of pack 电池组的储存.....	7
9.3. Charging pack 电池包充电.....	7
9.4. Protection from unexpected damaged to pack 防止电池包意外损坏	7
9.5. For Safety 安全条款	7

1. Application 应用

T.B.D.

2. Basic Information 基本信息

Description 描述:	Rechargeable LiFeCoPO4 battery pack 可充磷酸铁锂电池包
Cell Type 电芯:	32700-6Ah
PCM 保护板:	CT-PCM4S
Chemistry 化学成份:	LiFeCoPO4 磷酸铁锂
Cell configuration 电芯配置:	2P16S
Voltage Nominal 标称电压:	51.2V
Capacity Nominal 标称容量:	12Ah
Energy 能量:	614.4Wh
Additional Function 其它功能:	
Protection 保护:	<ul style="list-style-type: none"> A. Over Charge Protection 过充保护 B. Over Discharge Protection 过放保护 C. Over Current Protection 过流保护 D. Short Protection 短路保护

3. Electrical Characters 电气特性

Items 项目	Parameter 参数
Charging Method 充电方式	CC-CV 恒流恒压
Charging Voltage 充电电压	57.6V
Over Charging Protect 过充保护	3.65±0.05
Standard Charging Current 标准充电电流	2.4A (0.2C)
Max. Charging Current 最大充电电流	12A
Cut-off Charging Current 充电结束电流	0.24A (0.02C)
Standard Discharging Current 标准放电电流	2.4A (0.2C)
Max. Discharging Current 最大放电电流	36A
Max Peak Discharging Current 瞬间最大电流	100A (2S)
Discharging cut-off Voltage 放电结束电压	40V
Over Charge Current 过充电流	/
Over Discharge Current 过放电流	130±15A
Over Discharging Protect 过放保护	5.0±0.05
Internal Resistance 内阻	<150hm
balancing voltage 均衡电压	3.50±0.05V
balancing current 均衡电流	50±30A
Standard Charge Temperature 标准充电工作温度	0~45℃
Standard Discharge Temperature 标准放电工作温度	-20~60℃
Storage Humidity 存储湿度	65%RH not condensed (无凝结)
Storage Temperature 存储温度	-20~60℃
Weight 重量	About -kg

4. Certification 认证

T.B.D.

5. System Block Diagram 系统框图

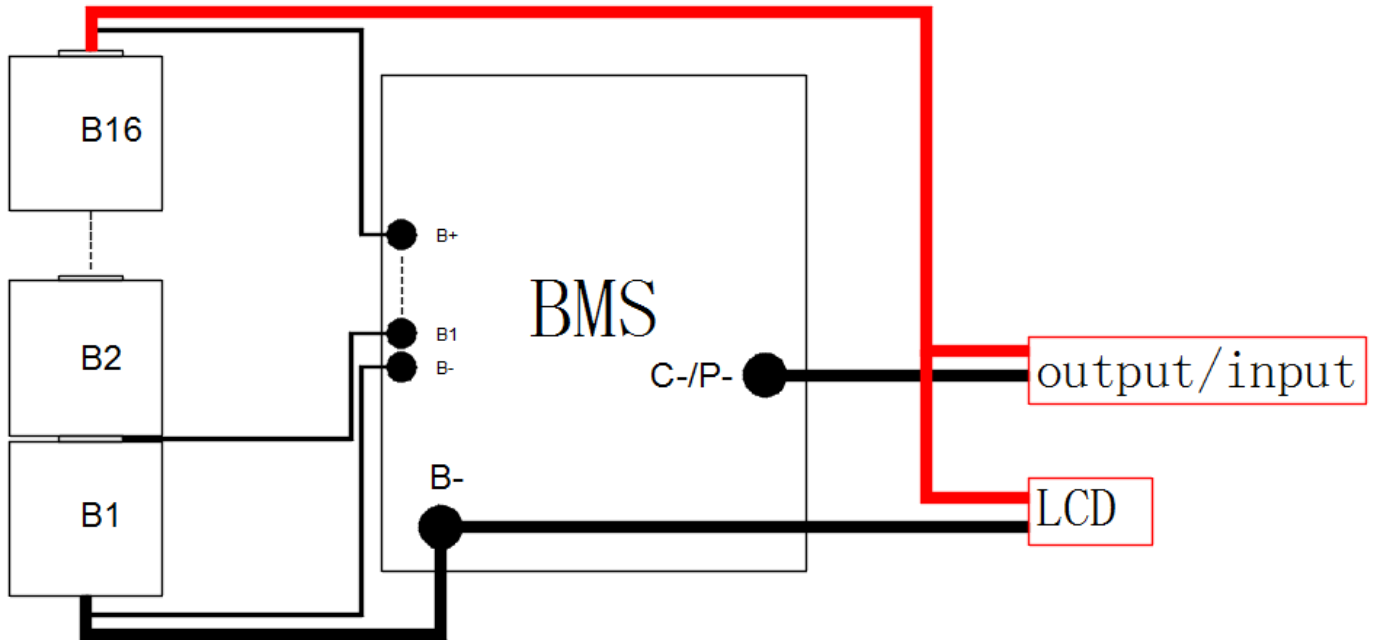

6. Mechanical Information 结构信息

6.1. Sample Picture 样品照

T.B.D.

6.2. Outline 外框信息

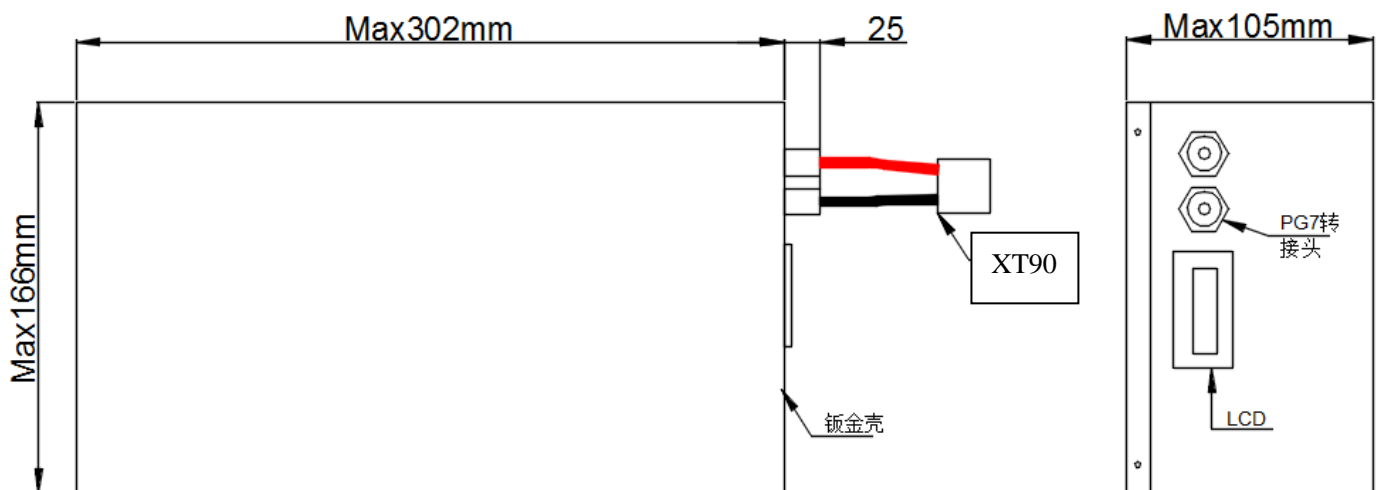

6.3. Pack Assemble 电池包组装要求

T.B.D.

6.4. Drawing of Label 标签图

CTECHI 标准 PET 哑银标签要求。标签长 70mm，宽 50mm。日期随出货时间更改，格式示例如下：



图样参考，实际
参数根据电池组
参数调整

6.5. 配件

配送一个充电器，欧规插头，输入电压 110-220V，输出电压 57.6V，输出电流 3A，输出头 XT90 公头母座，AC 线长 1 米，DC 线长 1 米

6.6. Packing 包装信息

T.B.D.

7. Caution and prohibition 注意事项

Before using and handling the pack, see carefully attached “Handling Instruction for Rechargeable Lithium ion battery Pack”. 在使用和处理包装之前，请参阅“可充电锂离子电池包的处理说明书”。

For safety reasons rechargeable batteries are not shipped in a low remaining capacity state. Charge before using.

为了安全起见，可充电电池禁止在低剩余容量状态下运输。使用前请充电。

Do not connect multiple battery packs as parallel or serials for using. This might damage the battery pack, even your equipment's.

请勿将多个电池组并联或串联使用。这可能会损坏电池组，甚至你的设备。

8. Warranty 保修

Manufacturer will be responsible for replacing the battery pack against defects or poor workmanship for 12 months from the date of shipping. Any other problem caused by malfunction of the equipment or misuse of the battery is battery is not covered under this warranty.

电池包从发货之日起 12 个月内出现缺陷或做工不佳等问题由厂商负责更换。任何由于设备故障或使用不当造成的问题，不在本保修范围之内。

9. Handling Instruction Guide for LiFePO4 Battery Pack 磷酸铁锂电池包使用说明书

9.1. General 总括

Battery packs supplied by CTECHI or CPKD have to be handle carefully according to the specification. Here are 20330-CT-51.2V12Ah Battery Pack Spec

some more to be followed.

CTECHI 或 CPKD 提供的电池包必须根据规格书正确使用。如下:

9.2. Storage of pack 电池组的储存

The packs are requested to be stored under the following conditions: 电池包请按以下条件下储存:

- a. Indoor storage in a cool circumstances without direct sun light on the packs or cartons.

存放在室内阴凉处, 禁止阳光暴晒。

- b. Store batteries in a dry location with low humidity, and a temperature range of - 20°C to +30°C. In case of the long term storage.

长期存放的情况下, 需将电池放在干燥(湿度低)的地方, 温度范围为-20° C 至+ 30°

- c. As long-term storage can accelerate battery self-discharge and lead to the deactivation of the batteries. To minimize the deactivation effect, store battery packs in a temperature range of +10°C to +30°C.

由于长期存储会加速电池自放电并导致电池的停用。为了最大限度地减少电池消耗, 请将电池包放在+ 10° C 至+ 30° C 的温度范围内。

- d. When charging for the first time after long-term storage, deactivation of the packs may have led to decreased capacity. Recover such packs to original performance through repeating several cycles of full charging and discharging.

长时间储存后首次充电时, 电池包的停用可能导致容量降低。通过重复几次完全充电和放电循环, 将这些电池包恢复到原始性能。

- e. When store packs for more than 6 month, charge at least once charging require per 6 months to prevent leakage and deterioration in performance due to self-discharging.

当电池包储存超过 6 个月时, 每 6 个月至少需要补电一次, 以防止由于自放电而造成的泄漏和性能下降。

9.3. Charging pack 电池包充电

- a. Use suitable charger with the specified voltage and current. We strongly recommend CTECH and CPKD smart battery charger. We can recommend the usage or specification of the charger manufacturing. If you want to get the information about it, please contact us.

使用指定电压和电流的合适充电器。我们强烈推荐使用 CTECH 和 CPKD 智能电池充电器。我们可以推荐充电器制造的规格和使用。如果您想获取有关信息, 请与我们联系。

- b. Never attempt reverse charging. Charring with polarity reversed can cause a reversal in battery polarity, causing gas pressure inside of the battery to rise, which can be lead to leakage of the batteries in the pack.

切勿尝试反向充电。极性反转的充电可能导致电池极性反转, 导致电池内部的气压升高, 这可能导致电池中的电解液泄漏。

- c. Avoid overcharging. Repeated overcharging can be lead to deterioration in pack performance. And Over-heat occurred.

避免过度充电。重复过充可能导致包装性能下降。导致电池过热。

- d. Charging efficiency drops at temperatures above 40°C.

充电温度在 40° C 以上会导致充电效率下降。

9.4. Protection from unexpected damaged to pack 防止电池包意外损坏

- a. (+) and/or (-) terminals must not be connected in metal wire, necklace, chains.

(+) 正极和/或负极 (-) 端子不得连接在金属线, 项链, 链条中。

- b. Do not drop packs from height in order to prevent them from possible malfunction or damage.

不要从高处抛掷电池包, 以防止它们发生故障或损坏。

- c. Do not twist or bend packs in order to prevent possible damage.

不要扭曲或弯曲电池包, 以防止可能的损坏。

9.5. For Safety 安全条款

- a. Do not disassemble packs. 不要拆卸电池包。

- b. Do not use pack when something abnormal found such as smells, deformation, discoloration, and so on.

出现异常现象时, 如气味, 变形, 变色等, 请勿使用电池包。

d. Do not re-use LiFePO4 cells or other parts after removing from the packs.

从电池包中取出后, 请勿重新使用磷酸铁锂电池或其他部件。

e. When the electrolyte leakage occurs, do not touch the liquid.

当发生电解液泄漏时, 请勿接触液体。

f. Once watered, packs may have potential malfunctions. Do not use those packs.

一旦碰水, 电池包可能有潜在的故障。不要使用这些电池包。

g. Do not have packs in the hot-temperature (60°C or more).

禁止在高温 (60° C 或更高) 下使用电池包。

h. Do not put packs into fire.

电池包禁止接触火源。

i. Do not crush/nail pack.

禁止碾压或钉子刺穿电池包

i. Do not apply solder directly to packs.

禁止将焊料直接焊在电池包上。