

# AGM START-STOP BATTERY

## AGM-L1 R (12V50Ah)



### CHARACTERISTICS

Item	Specifications	
Nominal Voltage	12V	
Nominal Capacity (20HR)	50Ah	
Reserve Capacity	80min	
Cold Cranking Amps@0°F (-18°C)	570A	
Dimension	Length	207mm (8.15inches)
	Width	175mm (6.89inches)
	Height	190mm (7.48inches)
Approx Weight	15.1kg (33.3lbs)	
Terminal	1	
Cell layout	1	
Hold-Down	B13	
Case	Black-PP Material	
Cover	Black-PP Material	
Handle	TS2	

### APPLICATIONS

- Car with start-stop system
- EV/HEV
- Engine start

### GENERAL FEATURES

- Maximum CCA and life
- Valve regulated technology
- Advanced Absorbed Glass Mat (AGM) technology
- Top-level safety - absolutely no free acid
- 2x Faster Charge Acceptance than conventional starter batteries
- 3x higher cycle life than conventional starter batteries
- Suit for working in partial state of charge operations (PSoC)
- OE quality certification

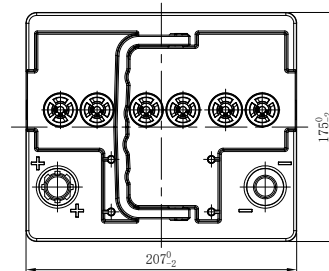
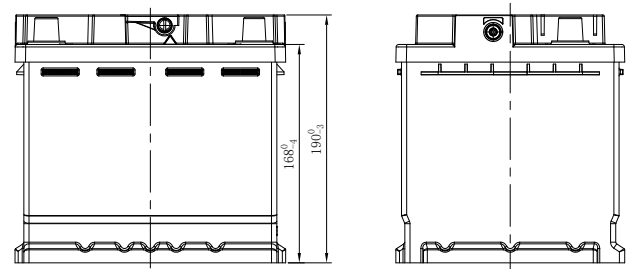
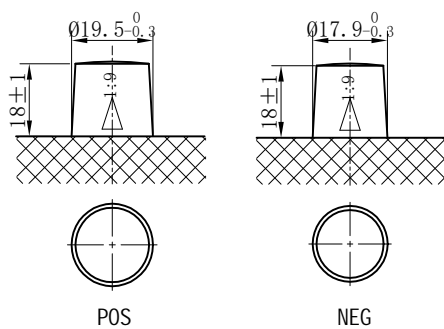

\*Values are subject to variation of +/- 5% in normal manufacturing processes.